

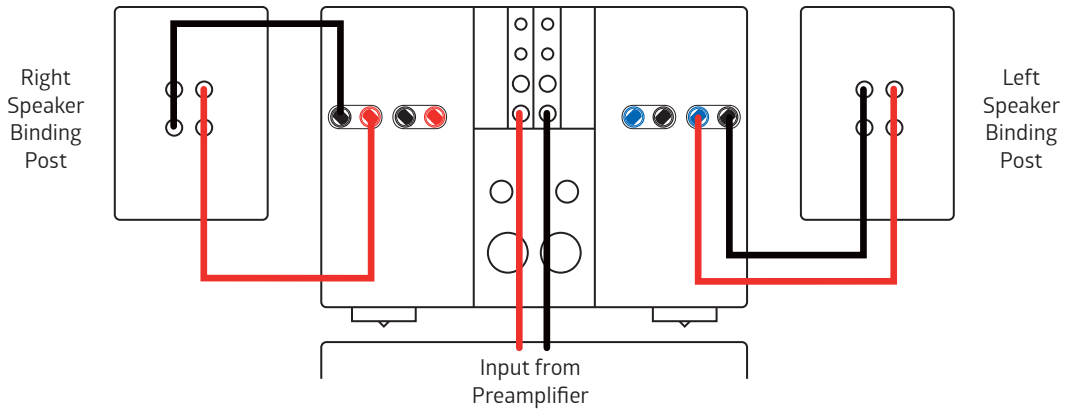

M10 Power Amplifier

System Topology Diagrams

M10 Power Amplifier – Stereo Mode



M10 Power Amplifier – Bridged Mode

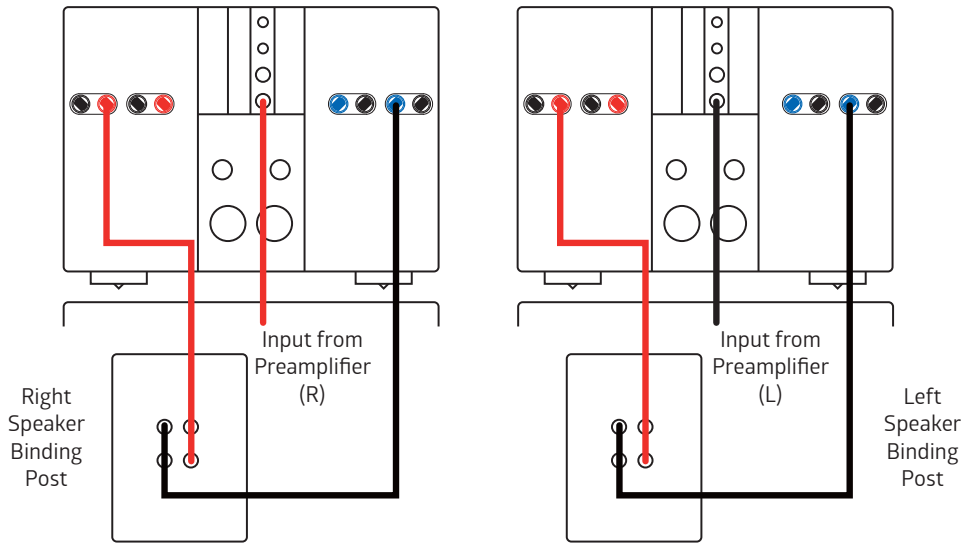

M10 Power Amplifier – Monaural Mode

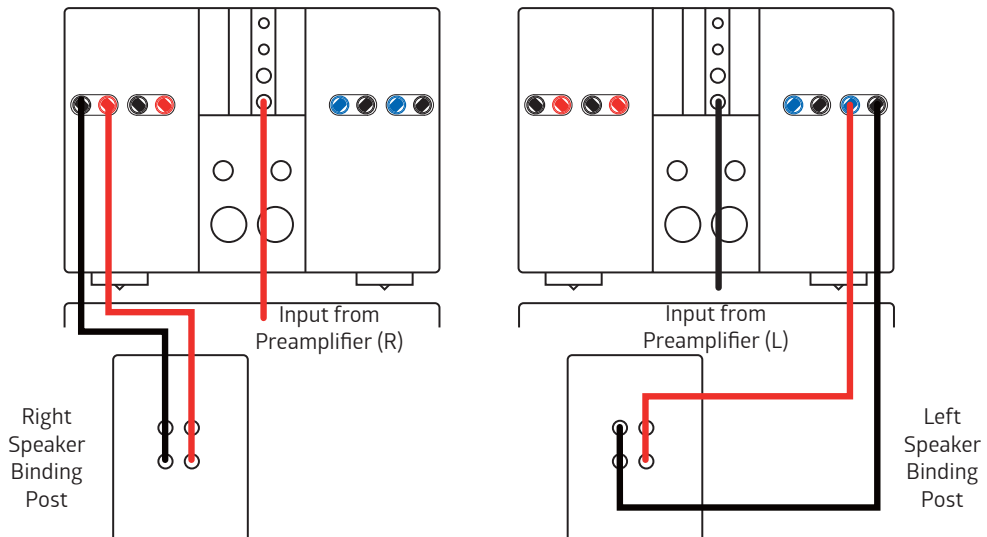



M10 Power Amplifier – Passive Bi-Amplification Mode

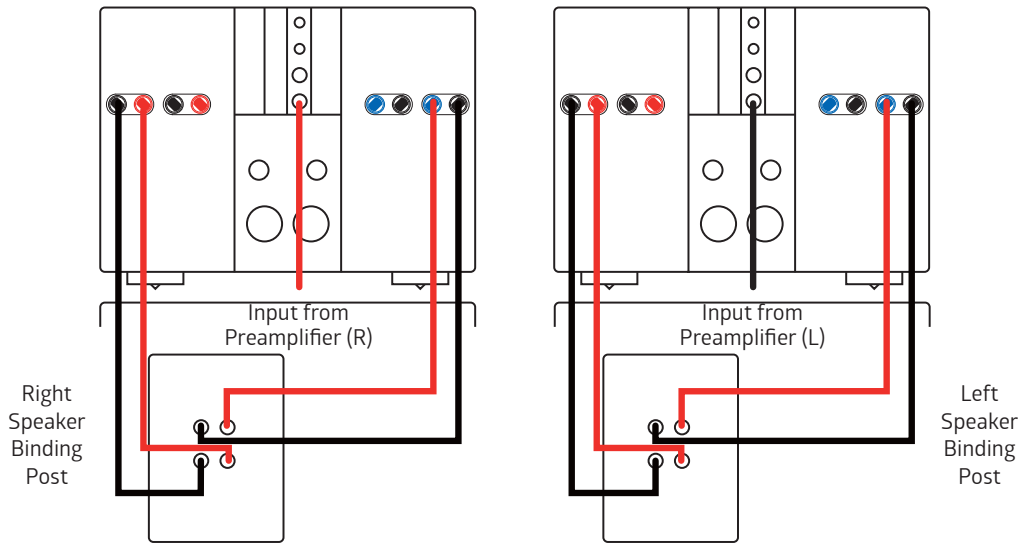

M10 Power Amplifier – Active Bi-Amplification Mode

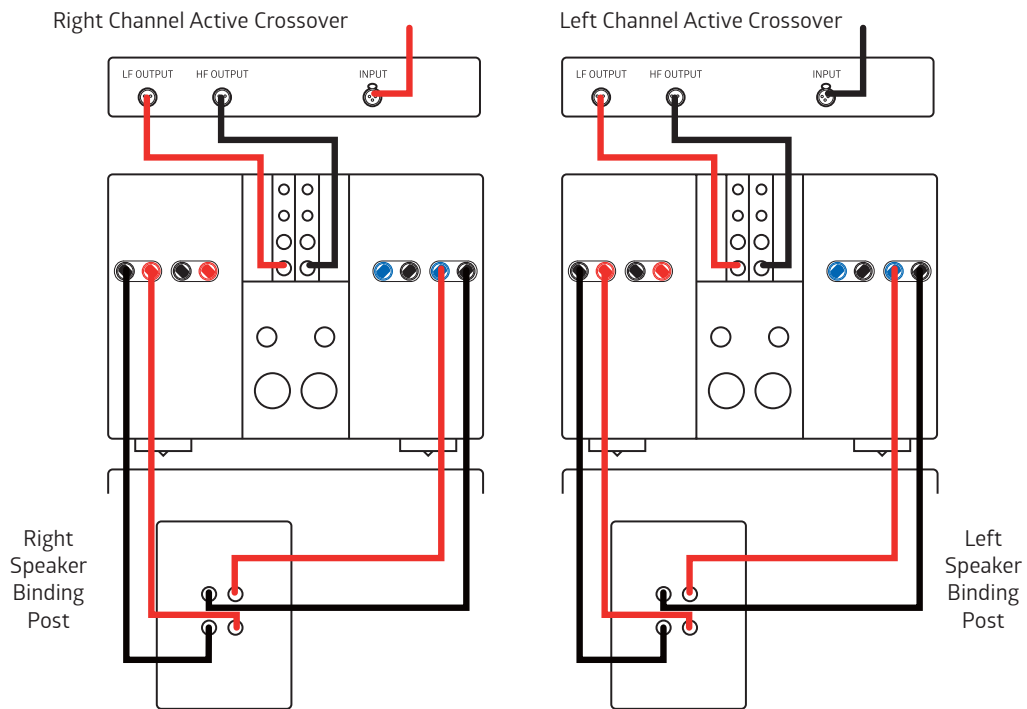

Please Note: Each channel on the M10 is fitted with two sets of binding posts. These outputs are identical and are provided to facilitate cable routing and bi-wiring.



CH PRECISION SÀRL

Z.I. LE TRÉSI 6D · 1028 PRÉVERENGES · SWITZERLAND

+41 (0)21 701 9040 · info@ch-precision.com

www.ch-precision.com